

## APPLICATION Retail Conversion Grant

Date application submitted: 3 Jan 2022

Date of pre-application meeting with LDDA/LEDP: 21 Sept 2021

City Sales & Use Tax License No: 12101-1110 Date issued: 07/2020

No. of existing employees (in Longmont, and globally if applicable): 7

No. of additional employees added as a result of this project (if applicable): 4

Business owner/operator: (Please include names of all owners/partners of the business)

Mike Root

Business name (with dba if applicable): Copper Sky Distillery

Business address: 110 Emery St

City/state/zip code: Longmont, CO 80501

*Note: Only businesses located in the LDDA are eligible for this grant program.*

Year business was established: 2020

Business phone: ( 720) 204-6064 Alternate phone: ( ) \_\_\_\_\_

Email address: mike@copperskydistillery.com

Description of type of business and products or services provided:

Distillery

Number of square footage to be occupied at conversion location: 6700/sf

Percent of products sold outside Boulder County, if applicable: \_\_\_\_\_

Description of eligible conversion improvements (attach additional sheets if needed)

Utility Upgrades

Remodeling

Restrooms

Accessibility compliance

Description of how the project is compatible with the Downtown Longmont Master Plan of Development and/or the Advance Longmont Strategic Plan (documents on-line, <http://www.downtownlongmont.com/about/master-plan>, <http://www.longmont.org/Advance-Longmont.aspx> or on request).

The location of the business resulting from the project at 110 Emery St. makes it accessible by transit projects, such as an RTD station and trails, currently planned in the nearby area. The leased space for this project is within an underutilized/blighted building. The remodeling of a former ButterBall plant buildings allows the preservation of Longmont's history while embracing change and preparing for the future. Further, the resulting business will provide variety in a mixed land use area. The business driving this project aligns with the development plan for an 18-hour, 7-day activity zone by providing space to congregate and socialize.

Total Project Cost (approximately): \$ 1,189,447

(Include all eligible grants costs and ineligible costs for the entire conversion project.)

If applicable, how much of this project cost is for equipment (approximately)? \$ 170,000

Total Retail Conversion Grant Costs \$ 345,693.00

(Include only project costs eligible in the grant.)

Total Grant Request: \$ 22,500

(25% of eligible project costs, maximum \$22,500)

Business Owner Applicant Name (Print or Type): Mike Root

Business Owner Signature: Mike Root

Date: 3 Jan 2022

If applicable:

Property Owner Applicant Name (Print or Type): \_\_\_\_\_

Property Owner Signature: \_\_\_\_\_

Date: \_\_\_\_\_

Submit completed application to the LDDA. Incomplete applications will not be accepted. Hard copy or electronic copy is allowed.

Del Rae Heiser, Downtown Specialist  
Longmont Downtown Development Authority  
320 Main St., Longmont, CO 80501  
Email: [delrae.heiser@longmontcolorado.gov](mailto:delrae.heiser@longmontcolorado.gov) / Phone: (303) 651-8586

**From:** [Mike Root](#)  
**To:** [Del Rae Heiser](#)  
**Subject:** [External] Fwd: 110 Emery Tenant Improvements  
**Date:** Thursday, February 10, 2022 9:36:20 AM

---

Here is approval from my landlord.

----- Forwarded message -----  
**From:** **Brian Bair** <[brian@masseq.com](mailto:brian@masseq.com)>  
**Date:** Thu, Feb 10, 2022 at 5:33 AM  
**Subject:** 110 Emery Tenant Improvements  
**To:** Mike Root <[mike@copperskydistillery.com](mailto:mike@copperskydistillery.com)>

Mike:

Please consider this email as approval from ownership for you to complete your Tenant improvements for your space per your Lease at 110 Emery.

Regards,

Brian

\*\*\*\*\*

Brian W. Bair, Manager  
110 Emery Owner, LLC  
263 2<sup>nd</sup> Ave, Suite 105  
Niwot, CO 80544  
(415) 269-2448

--

Cheers,

Mike Root | Founder & Owner

# LAPEYRE STAIR

Remodel

P.O. Box 50699 New Orleans, LA 70150  
 Phone: 504-733-6009 • Fax: 504-733-4393 • Toll Free: 800-535-7631  
 www.Lapeyrestair.com • email: LS.Sales@Lapeyrestair.com

## Quotation

**Addressed to:**

Keely Pellouchoud  
 LSE Builders Group  
 318 Main St  
 Longmont, CO 80501

**Shipping Address:**

Copper Sky Distillery  
 110 Emery St  
 Longmont, CO 80501  
 USA

Date	Quote No.	Account Rep	Account Manager	Terms
01/25/2022	TN-5266	Tyler Nobile		Net 30 days - upon credit approval

Short Description - see following page for detailed description	Qty	Unit Price	Extended Price
TN-5266-A: 120 Inch Model 03AA Stair, 192 Inch Floor Space, Closed Riser Stair	1	\$5,281.68	\$5,281.68
<b>Stair Total</b>			\$5,281.68

Estimated Freight (ALL SHIPMENTS FOB SHIPPING POINT, Harahan, LA). \$2,003.87

**QUOTE TOTAL** \$7,285.55

**EXCLUSIONS:** P.E. Stamped Engineering Drawings and Calculations are not included. We can provide a quotation for stamped drawings for some states if required. Contact your customer service representative for additional information.

**COMMENTS:** Pricing includes design drawings with up to two revisions. Additional drawing revisions may incur an additional fee.

**LEAD TIME:** LEAD TIME IS WITHIN 15 WORKING DAYS FABRICATION, PLUS SHIPPING. Please contact Lapeyre Stair regarding expediting services. See the detailed line item description below on the following page(s) for item specific lead time. Lead time begins from the time final drawing is approved.

**WRITTEN CONFIRMATION REQUIRED** to release order for fabrication. Any change to dimensions, size, handrail style, or type of stair will affect the price. The price shown is for the stair exactly as described in the detailed description on the following pages. Changes to design will result in pricing changes. Field verify dimensions prior to placing order.

**50% RESTOCKING FEE** on all changes or cancellations made more than 24 hours after order is released. Payable in U.S. Funds.

**\*\* Quotation subject to attached Lapeyre Stair's General Terms and Conditions of Sale.**

<p>Reference: Unknown                  Price Good For 30 Days.</p>	<p>Sales tax may be applicable. Please send certificate if tax exempt.                  VISA/MasterCard/American Express accepted.</p>
--	--

# LAPEYRE STAIR

## Item Details for Quote TN-5266

TN-5266-A  
Closed Riser Stair

---

Quantity: 1  
120 Inch Model 03AA Stair, 192 Inch Floor Space  
Stair Angle: 31.2184 Degrees  
Tread Width: 36.0000 Inches  
Front Reveal: 1 inch(es)  
Top Reveal: 1 inch(es)  
Stringers: 12 inch Carbon Steel/Primed  
Risers: 18 Risers - Diamond tread - Carbon Steel - Closed Risers  
Risers: Rise 6.6667 / Run 11  
Rails: 42" Guard Rails with 36 Balusters on Both Sides and 36" high Hand Rails (Box To Guard/Top Box To Guard Both Sides)  
Assembly: Unassembled  
Lead Time: 15 Business Days  
This stair is designed based on building code(s) IBC-2006 (Occupancy Type: All Occupany Types) requirements as outlined in the code(s).  
Please check with your local building code official to verify complete compliance with your local code.

Estimated Shipping Weights:  
Class 70: 1454 lbs

---

**TO PLACE ORDER - Sign below, sign each stair print, and return to Lapeyre Stair.**

### **IMPORTANT NOTICE:**

**BY SIGNING BELOW, BUYER ACKNOWLEDGES THAT THE ATTACHED DRAWINGS CONFORM FULLY WITH THEIR PRODUCT REQUIREMENTS. IF THIS IS NOT THE CASE, CONTACT LAPEYRE STAIR IMMEDIATELY.**

Approved By: \_\_\_\_\_ Company: \_\_\_\_\_ Date: \_\_\_\_\_

*All products will be manufactured as specified in the buyer-approved design prints. Buyer is responsible for field verifications. Please sign and return for final approval of dimensions and parts. Approval releases order for fabrication; quoted lead time commences upon receipt of signed approval prints.*

**Quote Number:** TN-5266-A

**Stair Model:** 03AA

**Building Code(s):** IBC-2006 (Occupancy Type: All Occupancy Types)

**Building Code Comments:**

This stair is designed based on building code(s) IBC-2006 (Occupancy Type: All Occupancy Types) requirements as outlined in the code(s). Please check with your local building code official to verify complete compliance with your local code.

The stair width you selected is allowed under your building code based on the occupant load requirements. If your occupant load is larger than listed, you may need a wider stair. Please see code section: 1003.3.3.1 Exception 1. Stairways serving an occupant load of less than 50 shall have a width of not less than 36 inches.

**GENERAL BUILDING CODE POLICY STATEMENT:**

"As Lapeyre Stair expands its product line to provide you with more options to meet your access requirements, we are striving to incorporate into our engineering design the flexibility and interchangeability of components needed to selectively meet the requirements of the various laws, standards, and building codes in operation in all parts of the world.

We also strive to provide you with real value in your access device purchase. To achieve the goal of providing you with real value, we will endeavor to provide you with design alternatives that will meet your local requirements. Because of the infinite complexity of knowledge required to understand the diverse requirements of all local political and geographic regions we have decided to offer products that in general can be selectively configured to meet the requirements of several of the primary United States, and International laws, standards, and building codes as described in their current or most recently issued editions.

And although we can not guarantee that a particular stair configuration will be accepted by your local authorities; we stand at the ready to quickly provide you with detailed drawings of our access devices, prior to your purchase, that you may submit for compliance approval. Your local architect, local building code officials, and your local codes are your best source of compliance specifications/recommendations at your location.

All capacity ratings for Lapeyre Stair conventional tread stairs are stated in terms of the live load capacity of the stair system with a given safety factor. Local wind, snow, and seismic rating requirements are not included in this capacity rating. Local requirements for these loadings, where applicable, must be considered by your local architectural or engineering professional."

**IMPORTANT NOTICE:**

**BY SIGNING BELOW, BUYER ACKNOWLEDGES THAT THE ATTACHED DRAWINGS CONFORM FULLY WITH THEIR PRODUCT REQUIREMENTS. IF THIS IS NOT THE CASE, CONTACT LAPEYRE STAIR IMMEDIATELY.**

Approved By: \_\_\_\_\_ Company: \_\_\_\_\_ Date: \_\_\_\_\_

*All products will be manufactured as specified in the buyer-approved design prints. Buyer is responsible for field verifications and code conformance according to this Building Code statement. Please sign and return for final approval of dimensions and parts. Approval releases order for fabrication; quoted lead time commences upon receipt of signed approval prints.*

# Lapeyre Stair

## Dimensional Print

Page 2 of 5

Date: 01/25/2022

STAIR QUOTE ITEM#: TN-5266-A

Quantity Required: 1

ATTN: Keely Pellouchoud

Estimated Unit Shipping Weight: 1454 lbs.

COMPANY: LSE Builders Group

Material & Finish: Carbon Steel/Primed

Longmont, CO 80501

RE: Unknown

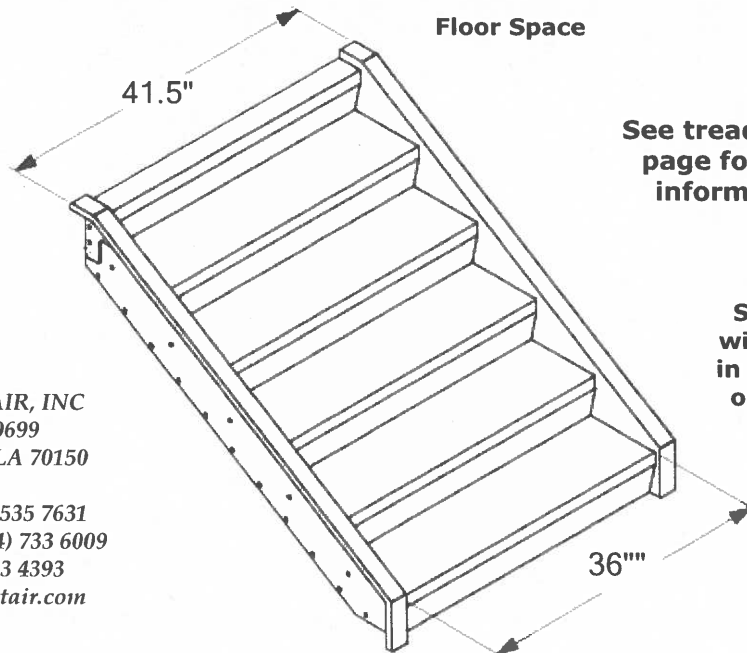
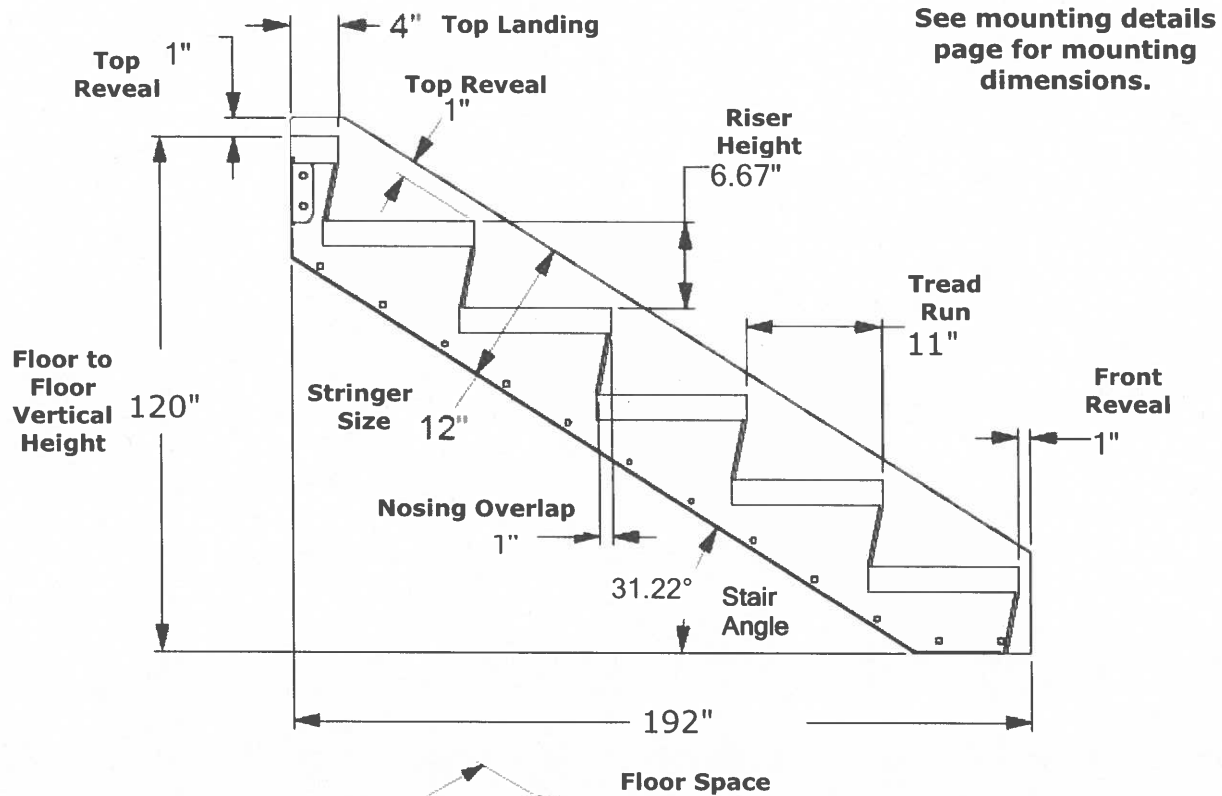

LAPEYRE STAIR, INC  
PO Box 50699  
New Orleans, LA 70150

Toll Free (800) 535 7631  
Local Phone (504) 733 6009  
Fax: (504) 733 4393  
[www.lapeyrestair.com](http://www.lapeyrestair.com)

**MOUNTING DETAILS**

ATTN: Keely Pellouchoud

COMPANY: LSE Builders Group  
Longmont, CO 80501

Date: 01/25/2022

LAPEYRE STAIR, INC  
 PO Box 50699  
 New Orleans, LA 70150

Toll Free (800) 535 7631  
 Local Phone (504) 733 6009  
 Fax: (504) 733 4393  
[www.lapeyrestair.com](http://www.lapeyrestair.com)

" A "   
 " A " 

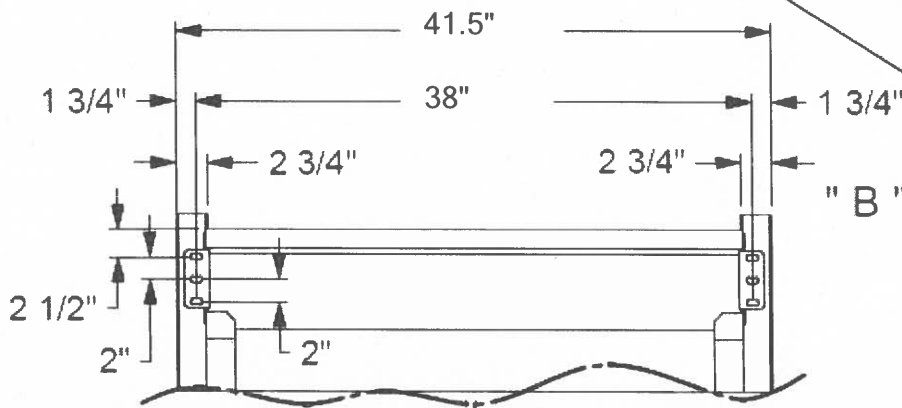
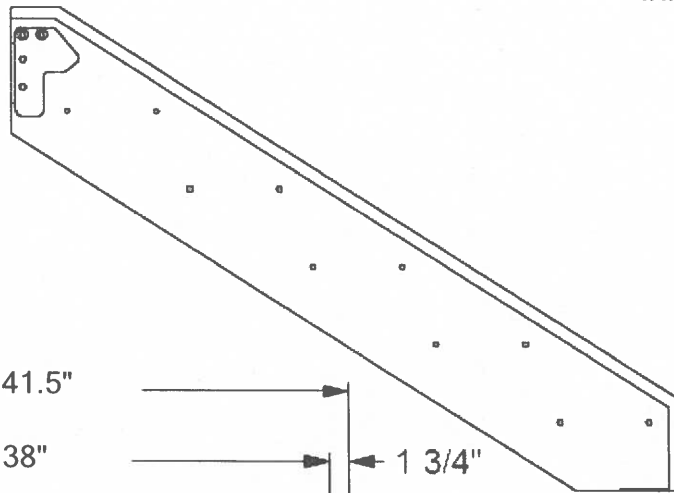

**VIEW " A - A "**

OPTION # 1, DIMENSIONS FOR MOUNTING BRACKET  
 WHEN BOLTED TO INSIDE OF STRINGERS  
 WITH FLANGE PLACED OUTWARD

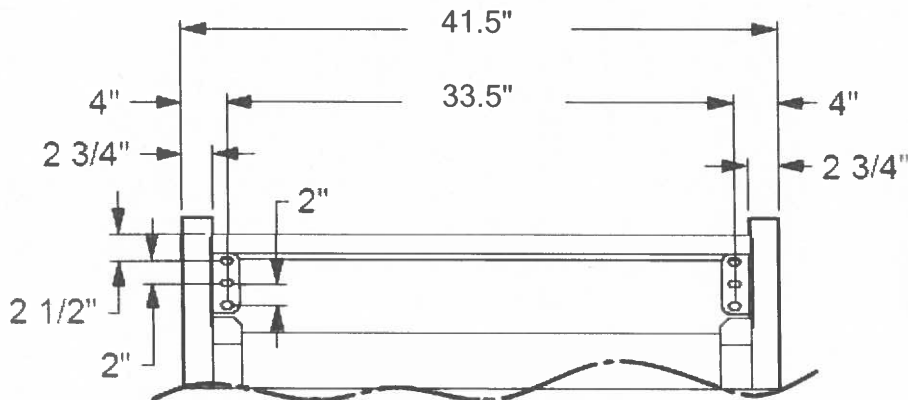

**VIEW " A - A "**

OPTION # 2, DIMENSIONS FOR MOUNTING BRACKET  
 WHEN BOLTED TO INSIDE OF STRINGERS  
 WITH FLANGE PLACED INWARD

" B "  " B " 

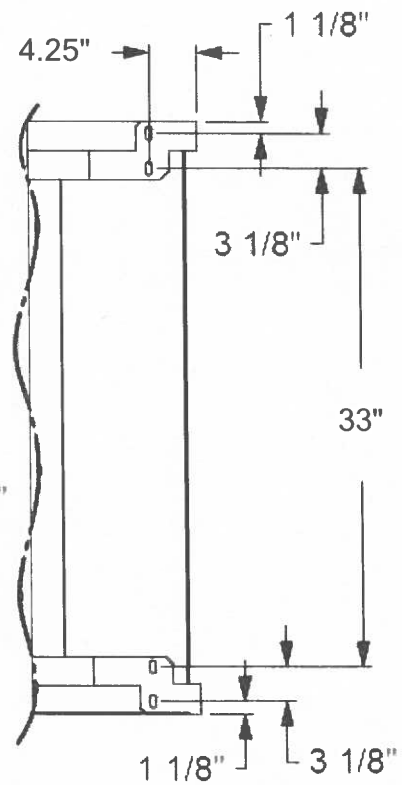

**VIEW " B - B "**



# Diamond tread

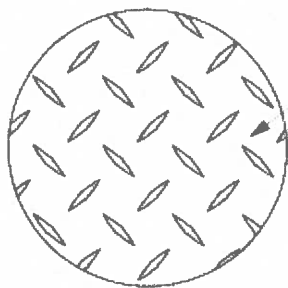
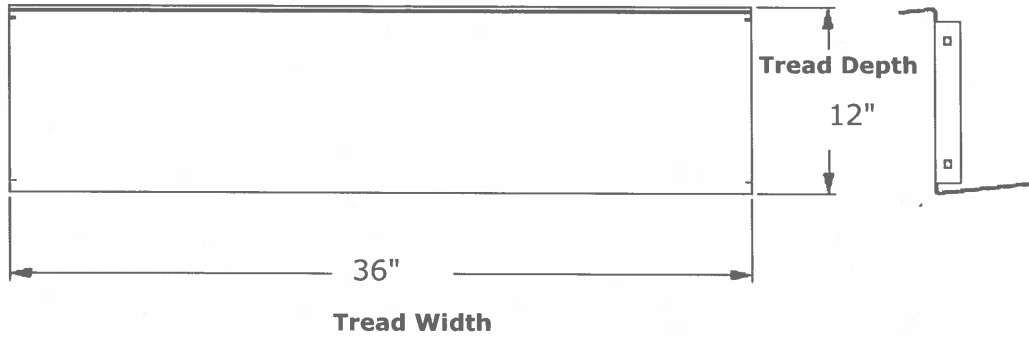

DIAMOND SAFETY PLATE. DIAMOND SURFACE NOT SHOWN FOR CLARITY. DIAMONDS .040" HIGH. OVERALL THICKNESS: ALUM = .290", STEEL = .228"

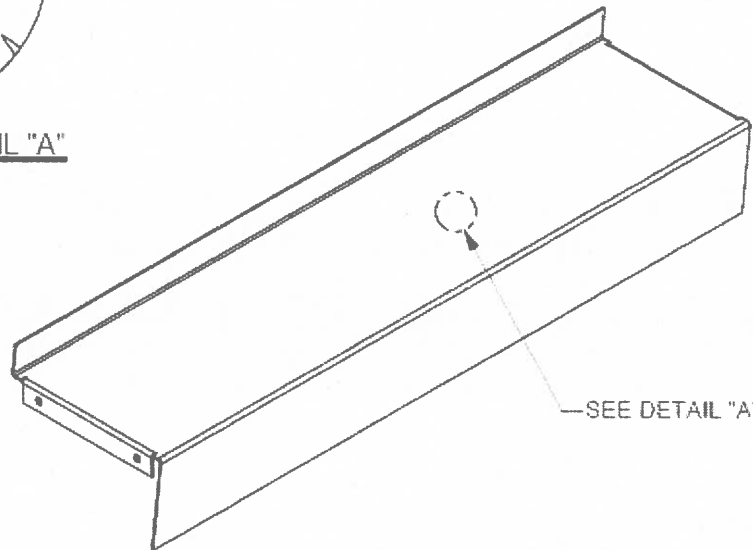

LAPEYRE STAIR, INC  
PO Box 50699  
New Orleans, LA 70150

Toll Free (800) 535 7631  
Local Phone (504) 733 6009  
Fax: (504) 733 4393  
[www.lapeyrestair.com](http://www.lapeyrestair.com)

Quantity Required Per Stair: 17

Material & Finish: Carbon Steel/Primed

ATTN: Keely Pellouchoud

COMPANY: LSE Builders Group

RE: Unknown

### Left and Right Rail Description

Material & Finish:  
Carbon Steel/Primed

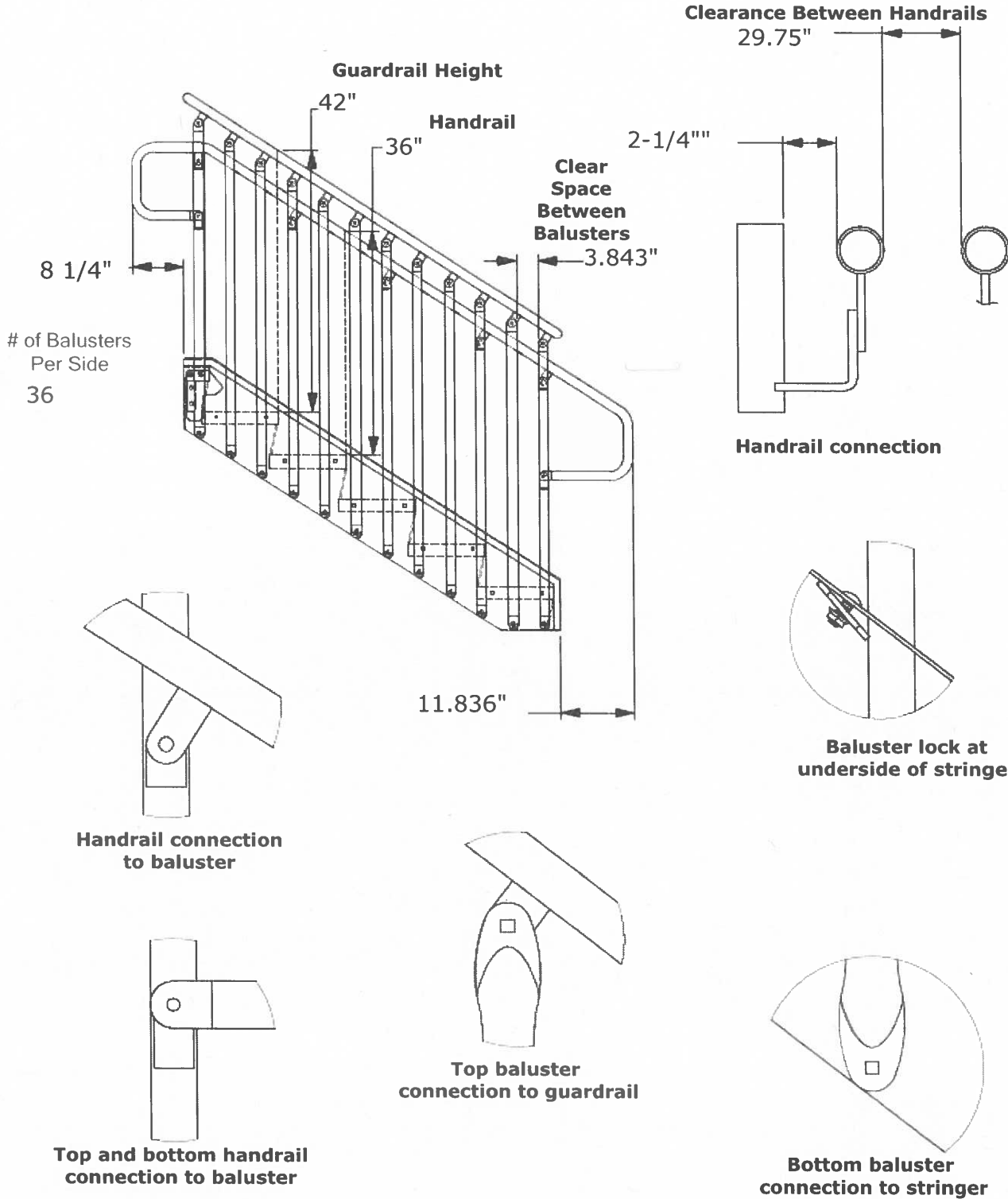



**SafeRack**<sup>®</sup>  
ORANGE. SAFETY HAS A NEW COLOR.

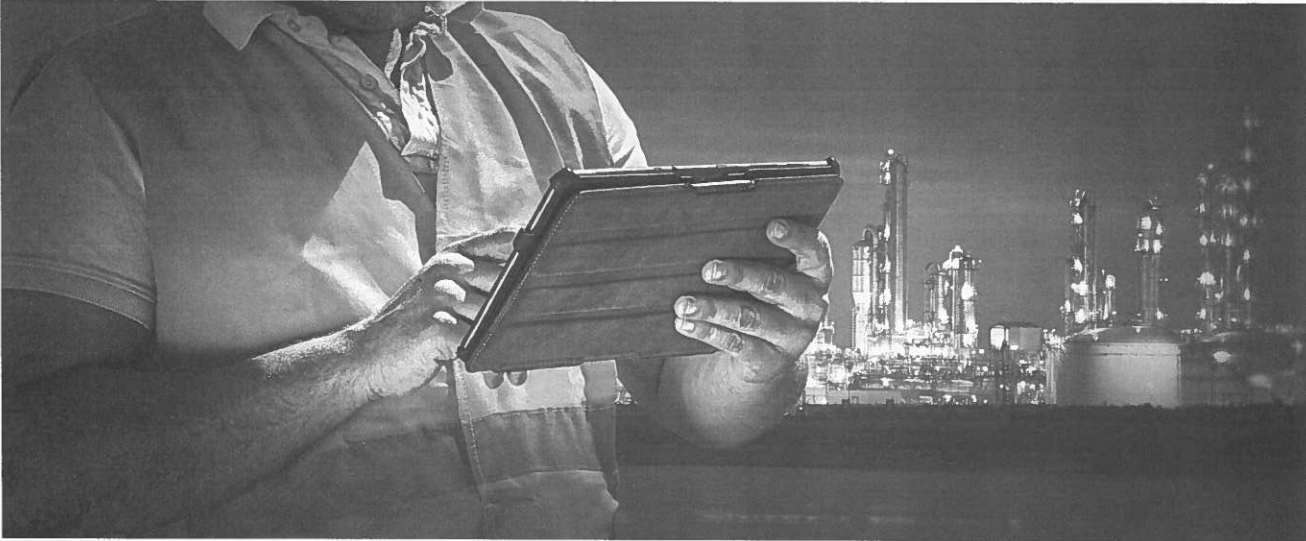

*remodel*

**LSE Builders Group - Longmont, CO - IBC Stair System - AS**

**LSE Builders  
Group**

Keely Pellouchoud

Longmont, CO 80501  
US

**Quote #SAS-113268R1**

January 28, 2022

**SafeRack, LLC**

730 Electric Drive, Sumter, SC 29153 | Phone (856) 761-7225 | info@saferack.com |  
<http://www.saferack.com/>

*# 2*



Date: Jan 28, 2022

Quote #: SAS-113268R1 Ship via: FOB

To: Keely Pelleuchoud  
LSE Builders Group  
  
Longmont, CO 80501  
US

From: Anthony Smith  
Inside Sales Representative  
SafeRack, LLC  
730 Electric Drive  
Sumter, SC 29153 USA  
(866) 761-7225  
asmith@saferack.com

### Description

LSE Builders Group - Longmont, CO - IBC Stair System

Thank you for choosing SafeRack for your access solutions needs; it was a pleasure preparing this quote for you. SafeRack is committed to creating the highest quality products for our customers. Our team pays attention to every last detail so you don't have to.

SafeRack is proposing a bolt-together system for ease in transportation and installation. Additionally, these are quoted using galvanized steel construction for superior performance and longevity.

Also quoted is our powder coated aluminum stair system as an option.

We look forward to working with you on this project and are here to answer any questions you may have.

Please note that taxes are not included

### Summary

Prices valid until Feb 7, 2022

Configuration Name	Quantity	Price
IBC Compliant Stair System With Landing (Mill Steel)	1	\$ 12,556.00
<b>TOTAL</b>		<b>\$ 12,556.00</b>

## Quote Details

Item	Part # / SKU	Description	Unit Price	QTY.	Extended Price
	4049	<b>IBC-Compliant Stair System With Landing (Mill Steel)</b>	\$ 12,556.00	1	\$ 12,556.00

IBC Compliant Stair Unit with Upper Landing

- \* IBC-compliant stair system will reach a finished floor to finished floor of 120 inches
- \* Stair treads measure 42 inches in width (occupancy must be less than 50 to remain in compliance with the IBC)
- \* Stair treads to be a diamond plate surface with a closed riser
- \* Stair treads to be spaced equidistantly across the entire stair span according to the exact finished floor to finished floor height without exceeding a maximum 7 inch rise height
- \* Landing to be 42 inches x 57 inches and includes 4 corner supports to grade
- \* Usage Orientation: user will walk up the stairs to the upper landing and will turn right to exit
- \* Includes (2) stringer handrails and (2) landing handrails
- \* Bolt together construction (no welding required)
- \* Mill steel (raw carbon steel) able to be independently sandblasted / painted / other finish as it will arrive on-site with surface oxidation. NOTE: Hot-dipped galvanized construction available
- \* Unit ships broken down (treads will need to be bolted to the stringers, landings bolted to the support legs, and stringers bolted to the landings and/or anchor points)

TOTAL

\$ 12,556.00

## TERMS AND CONDITIONS:

### ORDER SUBMITTAL OPTIONS

SafeRack, LLC Phone Orders: (866)761-7225 | Fax Orders to: (803)774-7232 | Email Order: [orders@saferrack.com](mailto:orders@saferrack.com)

SafeRack Construction Services, LLC Email Orders to [Orders@SCSLLC.com](mailto:Orders@SCSLLC.com)

**EXCEPT AS OTHERWISE AGREED IN WRITING, THESE TERMS AND CONDITIONS GOVERN ALL OUR CONTRACTS TO THE EXCLUSION OF OTHER TERMS AND CONDITIONS. OUR QUOTATIONS AND ESTIMATES ARE NOT OFFERS CAPABLE OF ACCEPTANCE BY YOU, AND ANY ORDER PLACED BY YOU WILL ONLY BE ACCEPTED BY OUR WRITTEN CONFIRMATION OF SUCH ORDER.**

### GENERAL PROVISIONS

- 1 The definition of terms used, interpretation of this agreement and rights of parties hereto shall be construed under and governed by the law of the State of South Carolina. "Seller" when used herein means **SafeRack LLC** "Purchaser" when used herein means the person, firm or corporation to whom this quotation is addressed. And "Equipment" or "Products" means those articles, supplies, drawings, data or other property or services described herein.
- 2 All quotations are for immediate acceptance and subject to change or withdrawal without notice before an order is acknowledged by Seller. This proposal shall not become effective until accepted by an authorized employee of the Seller. This proposal cannot be changed or varied by any verbal agreement. If this proposal is deemed to constitute an offer, it may be accepted only on terms set forth in this proposal, including, without limitation, these Terms and Conditions. If this proposal constitutes an acceptance of an offer, such acceptance is expressly conditioned on Purchaser's assent solely to the terms of proposal, including, without limitation, these Terms and Conditions. An acceptance of any part of the Equipment or services covered hereunder shall be deemed to constitute such assent. Any additional and/or different terms and conditions proposed by Purchaser and/or any attempt by Purchaser to vary any of these terms and conditions shall be deemed a material alteration and is hereby objected to and rejected.
- 3 Unless otherwise agreed by Seller in writing, Seller's prices are subject to change without advance notice at any time prior to order acknowledgment. Seller reserves the right to adjust the invoice price, after the price is quoted and/or acknowledged, to take account of any material variation in Seller's costs beyond Seller's reasonable control since the date of the quotation or (if no quotation is issued) the order acknowledgement, and the invoice so adjusted shall be payable as if the price set out therein were the original contract price. All sales are subject to increase without notification by the amount of any sales or excise tax levied or charged by any governmental agency and are subject to any price adjustment necessitated by Seller's compliance with any government action.
- 4 All sales under all orders and these terms and conditions are subject to Seller and/or Government priorities, laws and regulations, now or hereafter established.
- 5 The Seller reserves the right to change, discontinue or modify the design and construction of any product or to substitute material equal to or superior to that originally specified, without notice to the Purchaser.
- 6 All claims by Purchaser for shortages in a shipment of Equipment or Equipment damaged in transit must be made against the carrier. All claims by Purchaser against Seller for nonconforming Equipment and claims for shortages in a shipment or damaged Equipment (other than claims to be made against the carrier) must be made in writing to Seller within ten (10) days after receipt of shipment or thirty (30) days after date of shipment, whichever occurs first, or they are waived.
- 7 Any action for breach of the contract hereunder must be commenced within one year after the cause of action has accrued. Only variations or modifications to the contract which are made in writing signed by Seller and Purchaser shall be enforceable. Any failure by Seller to enforce its rights under this contract will not be deemed a waiver of such rights.
- 8 All disputes arising under or in connection with this Contract shall be resolved by (a) good-faith negotiations by knowledgeable, responsible representatives of each party who are fully authorized to settle any such dispute, or (b) in the event such negotiations do not resolve such dispute, binding arbitration held in South Carolina, by a single arbitrator pursuant to the Commercial Arbitration Rules of the American Arbitration Association. Each party shall bear its own costs of these procedures; the parties shall equally split the fees of the arbitration and the arbitrator. Notwithstanding the above, either party shall have the right to seek a temporary restraining order or an injunction related to the purposes of this Contract, to compel compliance with confidentiality obligations, or to file suit to compel compliance with this dispute resolution process.
- 9 Purchaser may not assign, novate or otherwise transfer its rights or obligations under this contract without Seller's prior written consent, and any attempt to do so shall be null and void and of no effect.

### CANCELLATION

Purchaser cannot cancel orders under any circumstances without Purchaser first reaching an agreement in writing with Seller covering all Seller's damages. At a minimum, such an agreement must reimburse the Seller for all expenses incurred (including but not limited to costs of purchased materials), engineering costs, and a reasonable mark-up to cover overhead and profit; cancellation charges shall be, at a minimum, at least 15% of the purchase price of the goods covered by the cancelled orders.

### ENGINEERING CRITERIA

The Equipment furnished by Seller are sophisticated engineering products; accordingly, Purchaser undertakes:

- 1 That it has provided and will promptly provide all the information reasonably necessary to enable Seller to (i) evaluate the requirements for performing and (ii) perform the Contract, and that all such information is full and accurate;
- 2 That all premises, plant, engineering support, spare parts, connected pipe work and machinery and inputs that it is required to provide for the design, engineering, installation, testing and use of the Products are fit for their purpose and of good engineering quality;
- 3 Fully to co-operate with Seller in the design, engineering, installation, testing and use of the Products;
- 4 To use the Products for the intended purpose only and in accordance with the Product literature; and not under any circumstances, to use any unapproved spare part, connected machinery, service or repair or use the Products in any manner as may render the Products dangerous and agrees that any breach of these negative criteria will negate all specific and implied conditions and obligations on the part of Seller relating to the quality of the Products;
- 5 Purchaser further agrees that it will be liable to Seller for any costs, expenses and losses it suffers by reason of any breach of these undertakings.

### DRAWINGS, DESIGNS AND CONFIDENTIALITY

- 1 All of Seller's specifications, designs, drawings, indications of physical, chemical and electronic properties and loads and reactions ("the Designs") are made in good faith and are approximate indications only and are not binding in detail unless Purchaser has specified in writing a particular indication upon which he is relying and Seller shall be entitled to vary the same and/or to correct errors and omissions provided the Products remain in substantial conformity with the contractual requirements.
- 2 The Designs (including all copyright, design right and other intellectual property in them) shall as between the parties be the property of Seller, and Purchaser is not entitled to make any use of the Designs other than for the purpose of this Contract.
- 3 Any inventions, modifications, improvements, techniques or know-how affecting the Products made or gained in the course of performing this Contract, shall belong to Seller absolutely.
- 4 Neither party shall disclose to third parties or use for its own purposes any confidential information or trade secrets of the other party.

### SHIPMENT, PAYMENT AND CREDIT

- 1 Credit Terms of Payment: A. Domestic - Net thirty (30) days from date of invoice. SafeRack requires deposits on orders \$100,000 and over with drawings as follows: 1/3 deposit on receipt of order - due upon receipt; 1/3 deposit upon receipt of signed drawings back from customer - due upon receipt; 1/3 at shipment - net 30. SafeRack requires deposits on orders \$100,000 and over without drawings as follows: 1/2 deposit on receipt of order - due upon receipt; 1/2 at shipment - Net 30. Delinquent accounts shall bear interest at 18% per annum thereafter, until paid. Said interest rate shall be reduced to the maximum permissible rate in any state having laws which so require. B. International - SafeRack requires payment before shipment on International orders. SafeRack requires deposits on orders \$100,000 and over with drawings as follows: 1/3 deposit on receipt of order - due upon receipt; 1/3 deposit upon receipt of signed drawings back from customer - due upon receipt; 1/3 before shipment. SafeRack requires deposits on orders \$100,000 and over without drawings as follows: 1/2 deposit on receipt of order - due upon receipt; 1/2 prior to shipment. Unless otherwise agreed to by the Seller's Manager of Credit and Collection, payment shall be in U.S. Funds by wire transfer or irrevocable Letter of Credit, confirmed by a major U.S. Bank, in addition to such late payment charges, Seller may add to the amount past due any costs associated with collection thereof, including reasonable attorneys' fees.
- 2 Seller may, in its sole discretion, accept payment for Products by cash in advance or by money-down with scheduled progress payments.

3. Shipments and deliveries shall be subject to approval of Seller's Credit Department. If Purchaser fails to fulfill the terms of payment, or if at any time before payment in full is made (whether or not payment is yet due) a petition is presented or resolution passed for the winding up or bankruptcy of Purchaser, or in the event of the appointment of a receiver or administrator of Purchaser's business, Seller may defer further shipment or at its option, cancel the unshipped balance. Seller reserves the right previous to making any shipments, to require from Purchaser satisfactory security for performance of Purchaser's obligation. No failure of Seller to exercise any right accruing from any default of Purchase shall impair Seller's right in case of any shipment default of Purchaser.
4. For domestic sales, freight terms are F.O.B. (as defined by the Uniform Commercial Code) Seller's plant unless otherwise expressly stipulated. Seller may in its discretion, select the carrier unless specified in advance by Purchaser. For international sales, freight terms are Ex Works (EXW, Incoterms 2010) Seller's plant unpacked and are subject to VAT or other taxes unless otherwise expressly stipulated. All applicable local taxes in the destination country are the responsibility of the Purchaser unless otherwise expressly stipulated.
5. Seller's responsibility for damages in transit ceases upon delivery of goods to carrier and Purchaser then assumes responsibility for damage determination and collection from carrier.
6. While expected dates of delivery of goods are given in good faith, the same are not of the essence of or in any way terms of the contract or representations of fact. All shipping dates given are approximate, and while effort is made to maintain schedules, Seller will not be liable for damages on account of delay. In case of delay by Purchaser in furnishing complete schedules or information, delivery dates may be extended for a reasonable time depending on factory conditions. The Seller shall not be responsible for reasonable or excusable delays nor shall the Purchaser refuse to accept delivery because of any such delays. Excusable delays include, without limitation, delays resulting from accidents, fires, floods, severe weather or other acts of God, strike, lockout or other labor difficulties, embargoes, government controls or other forms of intervention, inability to obtain labor, materials or services and other causes beyond Seller's control. If there is a scarcity in any of its products or goods, Seller will allocate its available supply in its sole discretion.
7. Title to the Equipment shall transfer to the Purchaser on the earlier of full payment and delivery; provided, however, that in the event delivery is prior to full payment, Seller shall retain a security interest in the Equipment until Seller receives payment in full. Pending payment of the full purchase price of the Equipment or parts furnished by Seller, Purchaser shall at all times keep the Equipment or parts comprehensively insured against loss or damage by accident, fire, theft and other risks usually covered by insurance in the type of business carried on by Purchaser in an amount at least equal to the balance of the price for the same from time to time remaining outstanding. In addition, the Purchaser undertakes not to charge by way of security any of the Products that remain the collateral of the Seller.
8. In the event of Cancellation in accordance with the provisions hereof, or in the event of non-payment (in full or in part) for the Equipment by the due date, Purchaser hereby irrevocably licenses Seller (insofar as it is able) to enter upon any premises to repossess the Equipment.

#### INDEMNITY

Purchaser will indemnify, defend and hold Seller, its affiliated companies and their respective directors, officers, employees and agents harmless from any loss, claim, cost, expense or damage (including payment of reasonable attorneys' fees) suffered or incurred by any of them and/or for which any of them may be liable to any third party due to, arising from or in connection with, directly or indirectly,

- (i) any violation of law, negligence, omission or intentional misconduct on the part of the Purchaser, its servants, agents or employees,
- (ii) Purchaser's instructions or lack of instructions or Purchaser's failure or delay in taking delivery,
- (iii) the breach of any provision of this Agreement by Purchaser; or
- (iv) any infringement or alleged infringement of patents, trademarks, copyright, design, right or other intellectual property right occasioned by the importation, manufacture or sale of the Equipment if made to the specification or special requirement of Purchaser.

#### LIABILITY

Seller's total liability for any and all claims, damages, losses and injuries arising out of or relating to Seller's performance or breach of any term herein shall not exceed the purchase price of the Equipment. IN NO EVENT, WHETHER IN CONTRACT, TORT OR OTHERWISE, SHALL SELLER BE LIABLE FOR LIQUIDATED, INDIRECT, EXEMPLARY, INCIDENTAL, SPECIAL OR CONSEQUENTIAL DAMAGES, EXPENSES OR COSTS, INCLUDING BUT NOT LIMITED TO: (1) LOSS OF PROFITS, BUSINESS OR GOODWILL, (2) LOSS OF USE OF EQUIPMENT OR FACILITIES, OR (3) LOSS RESULTING FROM UNUSABLE MACHINERY OR FACILITY DOWNTIME, HOWSOEVER CAUSED AND EVEN IF THE POTENTIAL FOR SUCH DAMAGES WAS DISCLOSED AND/OR KNOWN.

#### DISCLAIMER OF WARRANTY

SELLER DOES NOT WARRANT THE MERCHANTABILITY OF HIS PRODUCTS AND DOES NOT WARRANT THE FITNESS OF THE PRODUCTS FOR A PARTICULAR PURPOSE. SELLER DOES NOT MAKE, AND HEREBY DISCLAIMS AND EXCLUDES, ANY WARRANTY, EXPRESS OR IMPLIED, OTHER THAN THE WARRANTY CONTAINED HEREIN. THERE ARE NO WARRANTIES EXPRESS OR IMPLIED BEYOND THAT WHICH IS DESCRIBED BELOW.

#### WARRANTY OF GOODS MANUFACTURED BY SELLER

1. Except to the extent Seller specifies another warranty period in writing, Seller warrants products and parts manufactured by it and sold hereunder to be free from material defect in material and workmanship for a period of twenty-four (24) months from date of shipment (the "Warranty Period") provided, however, that Seller's sole responsibility under this warranty shall be to either repair or replace at Seller's option, any part which fails during the Warranty Period because of a defect in workmanship and material. Such replacement parts shall be provided at no cost to Purchaser, at the business establishment of Seller during regular working hours. Seller's obligation under this warranty shall not include any transportation charges, cost of installation, duty, taxes or any other charges whatsoever.
2. Seller shall be under no liability for breach of the warranty set forth herein: (i) unless the Equipment has been properly installed, used, maintained and serviced; (ii) unless Purchaser has promptly informed Seller in writing of the defect alleged within the Warranty Period and within 7 days of the discovery thereof; (iii) with respect to wearing and consumable parts; (iv) if Purchaser places Products in long-term storage and fails to perform proper long-term storage preparations per Seller's instructions; and/or (v) to Equipment or component parts or accessories thereof not manufactured by Seller.
3. Seller makes no representation regarding compliance with any state, provincial, or local law, rules, regulations, building code or ordinance relating to the installation or operation of the Equipment.
4. If the Purchaser informs the Seller of a defect after the Warranty Period has expired, then Seller may offer advice (free of charge) and may offer repair or replacement at Purchaser's expense. Any dispute as to whether a defect is covered by the Warranty shall be immediately referred to an expert to be agreed by Seller and Purchaser whose decision shall be final and binding upon the parties.
5. There are no third party beneficiaries of the Warranty granted by Seller herein.

#### WARRANTY OF OTHER MANUFACTURER'S PRODUCTS

Seller makes no warranties or representations of any kind whatsoever, either expressed, implied or statutory on any component parts or accessories sold hereunder which are not manufactured by Seller. Seller hereby extends the manufacturer's warranty or warranties, if any, given to Seller by the manufacturer of said component parts and accessories, but only to the extent Seller is able to enforce such warranty or warranties. Seller does not guaranty warranties of other manufacturers' products. Claims under any manufacturer's warranty shall be made in accordance with the manufacturer's requirements regarding the return, repair or replacement of the goods. Seller agrees to use its best efforts and will cooperate with Purchaser in enforcing any claims against manufacturer(s) for defects that may occur.

Seller has not authorized any party to make any representation or warranty other than the above warranty statements.

#### CONFLICTING LAW

Some jurisdictions provide rights in addition to those listed above, or do not allow the exclusion or limitation of implied warranties, or liability for incidental or consequential damages. If any provision or part of a provision of these terms is found to be illegal, invalid or unenforceable under any applicable law, such provision or part of a provision shall, insofar as it is severable from the remaining terms, be deemed omitted from these terms and shall in no way affect the legality, validity or enforceability of the remaining terms.

#### SPECIAL PROVISIONS

1. Purchaser understands and agrees that the Products may be subject to export and other foreign trade controls restricting re-sale and/or transfers to other countries and parties, including, but not limited to, licensing requirements under applicable laws and regulations of the United States (together, "Trade Control Laws"). Purchaser shall not export, re-export, transfer, or otherwise dispose of the Products directly or indirectly, except as permitted by applicable Trade Control Laws. Purchaser shall not do anything that would cause the Company or its affiliates to be in breach of applicable Trade Control Laws. Furthermore, Purchaser shall protect, indemnify and hold harmless the Company and its affiliates from any fines, damages, costs, losses, liabilities, penalties,

and expenses incurred by the Company as a result of Purchaser's failure to comply with this clause.



**QUOTE NOTES:**

**PROJECT NOTES:**

- \* Customer responsible for verifying supporting structure can support new equipment
- SafeRack will provide loads & reactions of the provided equipment for your use in determining if the existing structure can support the new equipment
- \* Customer responsible for moving any obstruction that interferes with operation of new equipment
- SafeRack will provide dimensional data of the provided equipment for your use to determine what items need to be moved
- \* SafeRack equipment and structures are designed by a competent engineer based upon appropriate codes and many years of experience
- \* No PE stamp is included
- \* International EndUser form is required to be completed in full for any order shipping outside of the US
- \* Equipment may protrude into standard clearance envelope
- \* Vehicles must be properly spotted for the SafeRack equipment to operate properly
- \* SafeRack will meet OSHA 1910 Subpart D - Any other code requirements may impact design and pricing
- \* Estimated Delivery Schedule:
  - Shipment: 8-10 week(s) after receipt of Purchase Order
- \*\*Please confirm delivery schedule prior to ordering equipment\*\*
- \* SafeRack manufactures our products with state of the art technology and sequencing to ensure the best quality product with fastest delivery possible.

Your equipment has been quoted with the most efficient and cost effective manufacturing process to enable your quoted price. Should any changes occur due to shipping or installation requirements that negatively impact manufacturing efficiency, it may impact the overall cost and price of your job

Once your approval process is complete and the manufacturing process has begun, subsequent changes in design/shipping/installation requirements may very well cause additional costs and charges even if those changes are later not implemented on the job. We will, of course, make every effort to support your delivery and installation requirements. In the event, however, these changes/costs are outside our quoted parameters, we reserve the right to re-quote the impact of these changes on your job

**NOTES/COMMENTS:**

- Some assembly required
- Quote does not include freight or special packaging (unless stated)
- Quote does not include installation (unless stated)
- Prices are in US dollars
- Prices do not include any applicable taxes or fees
- Galvanized steel specification meets ASTM 123.
- Upon receipt of goods, inspect all equipment for damage/missing pieces prior to acceptance from the freight company. If any damage/missing pieces are noted on the shipping papers, please notify SafeRack immediately

**PAYMENT TERMS:**

Credit Terms of Payment: A. Domestic - Net thirty (30) days from date of invoice. SafeRack requires deposits on orders \$100,000 and over with drawings as follows: 1/3 deposit on receipt of order - due upon receipt; 1/3 deposit upon receipt of signed drawings back from customer - due upon receipt; 1/3 at shipment - net 30. SafeRack requires deposits on orders \$100,000 and over without drawings as follows: 1/3 deposit on receipt of order - due upon receipt; 1/3 at shipment - Net 30. Delinquent accounts shall bear interest at 18% per annum thereafter, until paid. Said interest rate shall be reduced to the maximum permissible rate in any state having laws which so require. B. International - SafeRack requires payment before shipment on International orders. SafeRack requires deposits on orders \$100,000 and over with drawings as follows: 1/3 deposit on receipt of order - due upon receipt; 1/3 deposit upon receipt of signed drawings back from customer - due upon receipt; 1/3 before shipment. SafeRack requires deposits on orders \$100,000 and over without drawings as follows: 1/3 deposit on receipt of order - due upon receipt; 1/3 prior to shipment. Unless otherwise agreed to by the Seller's Manager of Credit and Collection, payment shall be in U.S. Funds by wire transfer or irrevocable Letter of Credit, confirmed by a major U.S. Bank, in addition to such late payment charges. Seller may add to the amount past due any costs associated with collection thereof, including reasonable attorneys' fees.

Utility Improvement



PROPOSAL

January 11, 2022

Project Code LM858
Project Name Copper Sky Distillery
Customer LSE Builders
Contact Name Steven South
Address 110 Emery, Longmont
Phone Number 303 264 8561
Email Address Steven South <steven@lsebuildersgroup.com>

SUMMARY OF WORK.

Everest Mechanical is pleased to submit the following proposal for your consideration.

Work to be performed:

PLUMBING

Plumbing New construction proposal for Distillery, details as below, adjusting for comments of Jan 10th, 2022

Table with 3 columns: S. No., PLUMBING DETAILS, MATERIAL QUANTITY. Lists items like KITCHEN SINK, LAVATORY SINK/FAUCET, TOILET, and Water Heaters with their respective quantities.

#1

1 CP-2 ReCirc	1
1 AAV- 1-1/ 1/2 SureVent W/PVC White Studor	2
1 IMB-1 Ice Maker Box with Arrestor	1
1 FD-1 2" PVC Floor Drain + Trap	4
1 FD-1 3" PVC Floor Drain + Trap	1
1 FD-1 4" PVC Floor Drain + Trap	1
1 FD-1 10" PVC Floor Drain + Trap	1
1 FS-1 Spigot 3" PVC Floor Sink+ Trap	5
1 WCO 4 NB Top PVC CL/OUT	8
Gas lines as per prints - @' to 1/2 "to 4" Lines ( approx 280 ft) + Regulators+ Isolation Valves, Hardware etc	1
1 Condensation Lines	4
1 Excavation, Bedding, & Backfill	1
1 Insulation - 500ft various sizes	1
1 Chlorination/ Water Bacterial Test	1
1 Storage Room - Drainage (Trench Drain)	1
1 DTV Valve	1
1 BackFlow Testing	1
1 Equipment Rental- Scissor Lift	1
1 Core Drilling 4 5" holes	1
1 Roof Penetrations- sub contracted out	6
1 Permits	1

**Total Plumbing Price \$ 113,904.88**

(One (1) year WORRY-FREE WARRANTY on parts and labor)

*Installation of the system would comply with the International Plumbing Code, Fuel and Gas Code, Mechanical Code, City building code, County building code, and engineering specifications.*

**Exclusions**

- No FCO's seen in Prints - only WCO
- No Roof Drains seen on Prints however P0.1 references insulation on Roof Drains
- No Concrete work
- No warranty or guarantee on fixtures and material provided by others
- Proposal good for 30 days
- Containment Tank
- DCOTG Valve for Containment Tank is excluded as not clear on prints

**Terms & Conditions**

- 1 Our payment terms are monthly progressive billing
- 2 All payments are due upon submission of the invoice and final billing will be issued close to the project.
- 3 This proposal is valid for 30 days from the date of submission.
- 4 Any modifications or deviation from the above specifications, involving additional charges, will be executed only upon written orders and will become an extra cost over and above the estimate.
- 5 All agreements are contingent upon strikes, accidents, or delays beyond our control. Fire, tornado, and all other insurance to be carried by the owner on the above work.
- 6 Workmen's Compensation and Public Liability Insurance on above work to be held by Everest Mechanical.
- 7 Any work and/or materials not listed above are considered to be excluded from the contract. All work beyond quoted scope will be charged separately on a time and material basis.
- 8 Any site conditions that cause delays to Everest Mechanical's scope of work may incur additional charges. If Everest Mechanical shows up to work at a job site and is not able to work due to access or any other hindrances outside our control, a (3) three-hour charge will be billed to the customer.
- 9 Scheduling of projects must be agreed to by both parties in writing a minimum of 2 weeks prior to work beginning. otherwise, the schedule cannot be guaranteed by Everest Mechanical. Additionally, changes to schedule by customers after the initial agreement must be re-approved by Everest Mechanical. Failure to adhere to this policy may cause delays that Everest Mechanical is not liable for.
- 10 Electrical work is limited to equipment within scope. All other electrical installations are excluded from the bid.
- 11 If permits are obtained by Everest Mechanical. the permit fees are outside the scope of this estimate and shall be billed independently.
- 12 No work shall be performed without written acknowledgment of acceptance of the contract.
- 13 The trip charge has been waived for the estimate. however, if the proposal is not accepted. we will bill for a trip charge.

- 14 Upon completion of project Everest, Mechanical and customer will schedule a walk-through inspection of work performed. Notification of walk-through must include Everest Mechanical operations and technical teams. Sign-off confirms that work has been performed to expectations, no further work is required, and the project is now closed. If the customer does not sign-off within 5 business days of walk-through, it is assumed that work is complete and accepted.
- 15 Any items installed, maintained, serviced, programmed, or adjusted by Everest Mechanical can only be maintained, serviced, programmed, or adjusted by Everest Mechanical or all warranties and guarantees are voided.
- 16 To hold the warranty, Everest Mechanical needs to perform check and service annually. This can be scheduled with us each season or alternatively by means of one of our annual preventative maintenance contracts details of which can be provided by calling us or checking with one of our technicians.

**Acceptance of Proposal**

The above prices, specifications, and conditions are satisfactory and are hereby accepted. You are authorized to do the work as specified. Payment will be made as outlined above.

Option(s) Selected: \_\_\_\_\_

Accepted By: \_\_\_\_\_

Signature: \_\_\_\_\_ Date: \_\_\_\_\_

We, Everest Mechanical appreciate the opportunity and look forward to working with you on the project. Please feel free to reach out to us if we can provide any additional information or answer any questions.

Sincerely,



Derek Shepard  
General Operations Manager

Utility

# CORMAN MECHANICAL CONTRACTORS INC.

1040 36<sup>TH</sup> STREET  
EVANS, COLORADO 80620  
(970) 330-2216 – FAX (970) 330-6220

## BID PROPOSAL

DECEMBER 23, 2021

ATTN: KEELY PELLOUCHOUD  
LSE BUILDES GROUP

JOB: **COPPER SKY DISTILLERY – LONGMONT**

THANK YOU FOR ALLOWING CORMAN MECHANICAL CONTRACTORS INC. THE OPPORTUNITY TO FURNISH A QUOTATION ON THE SUBJECT PROJECT. WE PROPOSE TO INSTALL A COMPLETE PLUMBING SYSTEM AS PER PLANS BY: **ASHER ARCHITECTS** DATED: **12-03-2021**

**PLUMBING EQUIPMENT TO INCLUDE:**

- SCH 40 PVC WASTE & VENT PIPING – CONNECT TO EXISTING MAIN
- TYPE L COPPER & PEX DOMESTIC WATER PIPING W/ INSULATION – CONNECT TO EXISTING
- SCH 40 BLACK IRON GAS PIPING FOR (1) MUA, (1) RTU, (2) WATER HEATERS, (1) GENERATOR, (1) BOILER, (2) UNIT HEATERS – CONNECT TO EXISTING METER
- CAST IRON UNDERGROUND WASTE PIPING TO CONTAINMENT TANK
- PLUMBING FIXTURES & EQUIPMENT TO INCLUDE:
  - (3) TANK TYPE WATER CLOSETS
  - (3) WALL HUNG LAVATORIES W/ MANUAL FAUCETS
  - (2) KITCHEN SINKS W/ FAUCETS
  - (2) MOP BASINS W/ FAUCETS
  - (1) HAND SINK W/ FAUCET
  - (7) FLOOR DRAINS
  - (5) FLOOR SINKS
  - (2) ICE MAKER BOXES
  - (1) AIR ADMITTANCE VALVE
  - (1) 100 GALLON GAS WATER HEATER W/ RECIRC PUMP
  - (1) 50 GALLON GAS WATER HEATER W/ RECIRC PUMP
  - (1) CONNECTION TO OWNER PROVIDED PREP SINK
  - (2) DISHWASHER CONNECTIONS
  - (1) CONNECTION TO OWNER PROVIDED BOILER
  - (1) CONNECTION TO OWNER PROVIDED & INSTALLED PRECAST CONTAINMENT TANK
  - FILLING IN OF EXISTING TRENCH DRAIN BY OTHERS
- ONE YEAR WARRANTY
- 2.9% SALES TAX

BASE BID **\$ 164,900.00**

**EXCLUSIONS:**

- LOCAL SALES TAX
- PERMIT FEES
- BONDS
- FIRE PROTECTION
- HVAC
- TEST & BALANCE
- SAW CUT / CONCRETE CUT
- REMOVAL & REPLACEMENT
- WALL CUT AND PATCH
- ROOF CUT AND PATCH
- UTILITIES BEYOND 5FT FROM THE BUILDING
- TEMPORARY HEAT
- TEMPORARY WATER
- PAINTING OF GAS PIPE
- EQUIPMENT PADS
- LINE VOLTAGE ELECTRICAL
- TEMPERATURE CONTROLS
- GAS METER
- GAS SERVICE LINE
- UNIT HEATERS
- WATER METER
- EXPORT OF EXCESS FILL
- EXCAVATION OF ROCK/SHALE
- DEWATERING
- FROST EXCAVATION
- PLUMBING DESIGN
- CONDENSATE DRAINS
- 3 COMPARTMENT SINK
- BOILER

**NOTE: DUE TO MARKET CONDITIONS WE CAN ONLY HOLD PRICING FOR 30 DAYS**

#2

Restrooms  
ADA



Dynamic Specialties  
PO Box 3118  
Loveland, Colorado 80539  
Phone: 970-663-0377  
Fax: 970-663-0030  
www.dynamicspecialties.net

Estimate

Date	Estimate #
1/24/2022	211274-R

Job / Location
Copper Sky Distillery Longmont, CO

Project	Addenda Acknowledged	Quoted By
Copper Sky Distillery	None	Tom

Item	Description	Qty	Amount
	Includes 2.9% Tax on Materials		
	Materials MUST SHIP before 3/31/2022 due to volatile market. Materials ordered early to protect price must be stored on site. Quotes for future 2022/2023 are budget and will need to be repriced post 3/31/2022		
	TOILET ACCESSORIES - No Spec By: American Specialties Inc.		
3801-18	18" Straight Grab Bar, 1-1/2" Dia., Concealed Mounting	3 Ea	
3801-36	36" Straight Grab Bar, 1-1/2" Dia., Concealed Mounting	3 Ea	
3801-42	42" Straight Grab Bar, 1-1/2" Dia., Concealed Mounting	3 Ea	
0030	Toilet Tissue Dispenser, Dual Roll, Surface Mount	3 Ea	
0210	Paper Towel Dispenser, Traditional Collection, Surface Mount	5 Ea	
ASI 0347	Soap Dispenser, Vertical Mount, Satin Finish Stainless Steel, 40 oz. Reservoir	5 Ea	
0620-2436	24" W x 36" H Glass Mirror, Stainless Steel Channel Frame	3 Ea	\$1,280.00 Total
Installa...	ADD for complete installation of above toilet accessories - Backing, blocking, cut-outs, caulking, and electrical by others	1 Lot	+ \$500.00 Total
	** RR 109 is existing - No Demo Notes included TA's in above count **		
	FIRE PROTECTION SPECIALTIES - No Spec By: Activar/ JL Industries		
FE10C	Cosmic 10E Extinguisher, 10 lb Dry Chemical, Multi-Purpose	Unit	\$113.00 Each
1017 F10	Ambassador Series Cabinet, Steel, Semi-Recessed with Rolled Trim, Non-Rated, Full Clear Acrylic Panel	Unit	\$135.00 Each
MB846C	Mounting Bracket for Cosmic 10E Fire Extinguisher, Chrome Straps	Unit	\$21.00 Each

~~\$1,780.00~~

FURNISH ONLY UNLESS OTHERWISE NOTED; SINGLE SHIPMENT TO ONE LOCATION - FREIGHT INCLUDED  
 INSTALL BASED ON SINGLE MOBILIZATION - ADDITIONAL MOBILIZATIONS WILL INCUR ADDITIONAL CHARGES  
 EXCLUDES ALL TAXES UNLESS STATED OTHERWISE - APPLICABLE TAXES NEED TO BE ADDED TO CONTRACT OR WILL BE ADDED WHEN INVOICING  
 QUOTE VALID FOR 30 DAYS - PRICE BASED ON QUANTITY, SIZE, MANUFACTURER, FINISH AND MODEL INDICATED  
 JOINT CHECKS MAY BE REQUIRED

#1



Dynamic Specialties  
 PO Box 3118  
 Loveland, Colorado 80539  
 Phone: 970-663-0377  
 Fax: 970-663-0030  
 www.dynamicspecialties.net

# Estimate

Date	Estimate #
1/24/2022	211274-R

Job / Location
Copper Sky Distillery Longmont, CO

Project	Addenda Acknowledged	Quoted By
Copper Sky Distillery	None	Tom

Item	Description	Qty	Amount
Installa...	ADD for installation of above extinguishers with cabinets or brackets - Backing, blocking, cut-outs, caulking, and electrical by others	Unit	\$25.00 Each

FURNISH ONLY UNLESS OTHERWISE NOTED; SINGLE SHIPMENT TO ONE LOCATION - FREIGHT INCLUDED  
 INSTALL BASED ON SINGLE MOBILIZATION - ADDITIONAL MOBILIZATIONS WILL INCUR ADDITIONAL CHARGES  
 EXCLUDES ALL TAXES UNLESS STATED OTHERWISE - APPLICABLE TAXES NEED TO BE ADDED TO CONTRACT OR WILL BE  
 ADDED WHEN INVOICING  
 QUOTE VALID FOR 30 DAYS - PRICE BASED ON QUANTITY, SIZE, MANUFACTURER, FINISH AND MODEL INDICATED  
 JOINT CHECKS MAY BE REQUIRED

ADA Restrooms



**COLORADO**  
SPECIALTIES

16161 Table Mountain Pkwy.  
Golden, CO 80403  
PHONE: (303) 595-9627

Date: 01/21/2022  
Version#20211115

### Copper Sky Distillery (Revision 1)

110 Emery Street, Longmont, CO 80501

Plans Dated: 12/02/2021  
Specifications Seen? No  
Bid To: Project Estimator  
Addenda #'s Seen: No  
Tax: 8.515%

Estimator: Vanessa Benchouaf  
Email: VanessaB@coloradospecialties.com  
Valid Until: 02/20/2022  
Est. Install Date: 6/1/2022

We propose to furnish labor and/or materials at the prices and terms designated to perform work to the extent as:

#### Toilet and Bath Accessories

\$ 4,280.00

Furnish and install the following Toilet and Bath Accessories:

Rooms: 103, 104, 109, 110

Manufacturer: Bobrick

Item	Description	Qty	Item	Description	Qty
290 2436	Welded-Framed Standard Glass Mirror, 24" x 36"	3	262	Surface-Mounted Paper Towel Dispenser, Tumbler Lock, 400 Towel	5
6806x18	1-1/2" OD Straight Grab Bar, Length 18"	3	6806x36	1-1/2" OD Straight Grab Bar, Length 36"	3
6806x42	1-1/2" OD Straight Grab Bar, Length 42"	3	2888	Surface-Mounted Multi-Roll Toilet Tissue Dispenser	3
4112	Surface-Mounted Soap Dispenser, Satin Finish	5			

#### Toilet and Bath Accessories Qualifications:

- Manufacturer/model not specified. Pricing includes Typical, Stocked Materials as typically required for locations seen. Please review and advise if any Materials, Manufacturer's, Models, or features are to be revised prior to award.
- ADA Required Trap Wrap Excluded.
- Pricing includes Single Mobilization for installation of all materials within this scope. Please advise if phasing or demobilization will be required for this scope.
- EXCLUDES: Layout and installation of in-wall blocking/backing, and recessed rough openings (if applicable).

Total \$ 4,280.00

#2



**Additions to Contract**

- Due to the Worldwide COVID-19 crisis (and unexpected material shortages generated as a result), there is a possibility of delayed shipping dates and pricing fluctuations due to Manufacturer's raw material availability and costs. We ask for your patience as we all maneuver through this transitional period.
- Retail Vendor pricing can not be held and is an estimate of pricing at time of order, actual cost will be billed upon ordering. Pricing and Availability subject to change without notice. Subcontractor not liable for decisions by manufacturer outside of Subcontractor's Control.
- Lead times for material begin after field measurements are completed and submittals (including applicable finish selections) are approved. Thus, lead times may vary from initial information provided at approval of contract.
- Two-to-three-week notification required prior to mobilization.

**Terms & Conditions**

1. Pricing is valid for 30 days from the date of this proposal, unless noted otherwise.
2. Payment Terms: Companies without Net 30 Days will be subject to 100% deposit of contract amount upon ordering materials. Acceptable forms of payment are credit card, check, or cash.
3. Pricing herein may include requested Tax Exemptions. Sales Tax is estimated/per request, and actual will be billed. If Tax Exempt, resale, exemption certificate, or proof of Use Tax paid for all taxing jurisdictions required with order. If not provided prior to billing, Costs will be billed at Full Tax Rate for the Jurisdiction.
4. Proposal to be signed by authorized Purchaser of accepting company.
5. Shipment projections are estimated per the manufacturer, and are contingent upon availability of necessary material. Such projections are based upon Colorado Specialties and/or Snyder Equipment receipt of approved shop drawings together with all necessary field dimensions and release information. Subsequent changes to drawings, dimensions or other criteria may revise shipment projections.
6. Quotes exclude any bonding requirements unless specifically noted.
7. There shall be no liability on Colorado Specialties' and/or Snyder Equipment's part for any delay in the delivery of material or any delay caused by strikes, fires, government regulations, pandemic delays, or any other causes beyond Colorado Specialties' and Snyder Equipment's control.
8. Prices are based on quantities shown on Plans/Specifications, Unless Noted Otherwise, and are subject to change upon revisions.
9. Prices are firm against escalation for 30 days from the date of this quote and upon acceptance for shipment within 3 months. Bronze, stainless steel, and market driven products are firm against escalation for 15 days from the date of this quote and upon acceptance for shipment within 1 months thereafter. Orders shipped beyond those deadlines are subject to escalation of current market value, and will be invoiced at time of shipment.
10. Cancelled Materials Orders or Projects are subject to charge of incurred costs of materials, including Freight/Restocking fees, and administration costs.
11. Once Materials have been approved in Submittal Response, materials are non-Cancellable, non-returnable, and non-refundable. RETURNS WILL NOT BE ACCEPTED.
12. Manufacturer's standard Material warranty applies. Colorado Specialties and/or Snyder Equipment's one year workmanship/installation warranty applies. Please, refer to warranty documents.
13. Material Only Contracts: If Dropshipped, Quotes exclude all onsite work or Requirements, including but not limited to: Insurance, receipt, any site access requirements, unloading, handling, storage, and installation of materials on the jobsite. Customer is responsible for receiving, unloading, and inspecting materials and filing freight claims for any shortage or damage of materials along with any exclusions made in the aforementioned statement. The quote and/or proposal does not include delivery and freight charges unless otherwise stated in the proposal, and all materials will be made available at Subcontractor's Will Call Pickup Location.
14. Insurance: Colorado Specialties and/or Snyder Equipment maintains insurance and will procure requested documents adhering to its insurance policy for all "Furnish and Install" Jobs. "Other Controlled Insurance Programs" not included UNO.
15. Certain Scopes may require a deposit on material. Please see qualifications for more information.
16. Field measurements are required for stainless steel wall panels, toilet partitions, operable wall, lockers, and other custom-designed products that may not explicitly be called out in the above Proposal. For some long lead items where field measuring substrate is not a viable option for the Schedule, Contractor will require other Subcontractors to "Hold Dimensions" as provided by Colorado Specialties.
17. Colorado Specialties and/or Snyder Equipment assumes no responsibility for manufacturer delays beyond its control (including freight damage), nor does it accept the terms for liquidated/delay damages that may arise from such Manufacturer Decisions or Ability defects.
18. Lead times for material begin after field measurements are completed and submittals & Final Shop Drawings (including applicable finish selections) are approved. Thus, lead times may vary from initial information provided at approval of contract.
19. Excludes demolition unless noted otherwise in the aforementioned scopes of work.
20. Contract can be accepted in its entirety, or select item groups based on General Contractor's needs (unless otherwise noted). If customer requires revisions prior to Award, please contact the estimator (Listed at the top of this proposal) for any changes or adjustments.
21. Drawings explicitly not in the architectural drawings are null and void to the quantities and types of items listed in the above proposal. A change order will ensue after the acceptance of individual, alternate, or contract total(s).
22. Walls to be prepared by others and confirmed ready by others prior to request for mobilization, including blocking, cut-outs in drywall, primer, and any other Substrate Finishes, if necessary.
23. Should any item(s) be required that is not called out herein; the item(s) will be handled as a change order or revised proposal.
24. Scanning, X-Ray or GRP required for Post Tension Cable or Utility Location by others. General contractor is to locate and mark locations of all existing pre / post tensioned slabs, and providing said layout with Submittal Responses. Subcontractor holds no liability for materials or work beyond the immediate substrate of installation and will not be held liable for damages or rework to these areas or materials, unless advised in writing to the Material's / work's Existence and Exact Locations.
25. If Colorado Specialties is scheduled onsite, and can not perform the work requested due to site conditions, Substrate Preparation Deficits, or available space, remobilization fee will be assessed via change order, minimum of \$350.00, or installation is to be performed by others.
26. Verification of "City Standard" Bike Rack types to be by others. Colorado Specialties takes no responsibility if materials requested do not meet governing standards.
27. Any required Finish caulking or fire caulking required by project beyond material manufacturer's standard installation instruction is to be by others and is excluded from this pricing.
28. Please be advised that some pricing may be the result of Volume or discount pricing. Colorado Specialties/Snyder Equipment can not guarantee the continuation of these discounts if change orders affect volume of, or type of materials.
29. Should Field Direction by Contractor/Ownership vary from Plans or Manufacturer Standard Installation, Contractor must authorize the change in writing, and accept possible voidance of warranties. Subcontractor is not liable for any cost/damages associated with proceeding with changes as specified by Contractor/Ownership, regardless of cause.
30. All Conflicts between installation materials and concealed, in-wall/in-floor Materials to be responsibility of Contractor, and Subcontractor will hold no liability for conflicts / rework of Materials if required.
31. Force Majeure: No Party to this Agreement shall be responsible for any delays or failure to perform any obligation under this Agreement due to acts of God, outbreaks, epidemic/pandemic or the spreading of disease or contagion strikes or other disturbances, including, without limitation, war, insurrection, embargoes, governmental restrictions, acts of governments or governmental authorities, and any other cause beyond the control of such party. During an event of force majeure, the Parties' duty to perform obligations shall be suspended.

Terms: 100% Upfront Pre-payment of Contract Value required (if no previous terms have been extended). Total Contract Value Due Upon Award.

Name of customer's representative authorized by the undersigned to approve and sign all material and labor reports used as a basis for invoicing: If required by the customer.

Date Accepted: \_\_\_\_\_

Company: \_\_\_\_\_

Name: \_\_\_\_\_

Title: \_\_\_\_\_